



Crawford 542 Overhead sectional door

Copyright and Disclaimer Notice

Although the contents of this publication have been compiled with the greatest possible care, ASSA ABLOY Entrance Systems cannot accept liability for any damage that might arise from errors or omissions in this publication. We also reserve the right to make appropriate technical modifications/replacements without prior notice.

No rights can be derived from the contents of this document.

Color guides: Color differences may occur due to different printing and publication methods.

ASSA ABLOY, Crawford, Megadoor and hafa, as words and logos, are examples of trademarks owned by ASSA ABLOY Entrance Systems or companies within the ASSA ABLOY Group.

Copyright © ASSA ABLOY Entrance Systems 2006-2013.

No part of this publication may be copied or published by means of scanning, printing, photocopying, microfilm or any other process whatsoever without prior permission in writing by ASSA ABLOY Entrance Systems.

All rights reserved.



Technical facts

Features

Max size: (W x H)*	8000 x 6000 mm
Panel thickness:	42 mm
Panel material:	Microrilled steel or aluminium
Filling:	CFC-free polyurethane
Weight:	Steel: 13 kg/m ² Alu: 10 kg/m ²
Colour outside:	9 Standard RAL colours
Colour inside:	RAL 9002
Track types:	Standard: SL Optional: HL, LL, VL
Windows:	Optional: DARP, DAOP
Passdoor:	Optional: In door leaf with Low threshold and Standard threshold
Electrical operation:	Optional: Automated operation, Access control, Safety functions

*On request available up to 10000 x 6000 mm

Performance

Opening/closing speed:	CDM9: 0,25 m/s CDM9 HD: 0,18 m/s CDM9 2H: opening 0,5 m/s, closing 0,25 m/s
Life time expectations:	Door: 100.000 door cycles Springs: 20.000 door cycles
Resistance to Wind load, EN12424	Class 3 (\leq 4250 mm DLW)* Class 2 ($>$ 4250 mm DLW)*
Thermal transmittance, EN12428	0,96 W/(m ² .k) Steel door (Door surface 5000 x 5000 mm) 1,14 W/(m ² .k) Alu door (Door surface 5000 x 5000 mm) 1,20 W/(m ² .k) With windows/passdoor (4000 x 4000 mm)
Resistance to Water penetration, EN12425	Class 3
Air permeability, EN12426	Class 2
Acoustic insulation, EN ISO 717-1	R=23dB

*Higher wind load classification on request

Contents

Copyright and Disclaimer Notice	2
Technical facts	3
Contents	4
1. Description	6
1.1 General	6
1.1.1 Standard	6
1.1.2 Options	6
1.2 Door leaf	7
1.2.1 Construction	7
1.2.2 Material	7
1.2.3 Colors	7
1.2.4 Seals	8
1.2.5 Wind reinforcement truss	8
1.2.6 Handle	9
1.2.7 Locks	9
1.2.8 Windows	10
1.2.9 Fixed sections	11
1.2.10 Passdoor with low threshold	12
1.2.11 Passdoor with standard threshold (180 mm)	13
1.3 Track sets	14
1.3.1 General	14
1.3.2 Standard lift	14
1.3.3 Standard lift low	14
1.3.4 High lift	15
1.3.5 Low lift	15
1.3.6 Vertical lift	15
1.3.7 Special track sets	16
1.4 Balancing system	17
1.4.1 Safety devices	17
1.5 Operating system	18
1.5.1 Types of operation	18
1.5.2 CDM9 Operator - 900 Door control systems	19
1.5.3 Access and automation	21
1.6 Monitoring systems	24
1.6.1 Saving energy	24
1.6.2 Security enhancement	24
1.6.3 Dock management	24
1.6.4 Facility management	24



2.	Specifications	25
2.1	Dimensions.....	25
2.1.1	Daylight width and daylight height.....	25
2.1.2	Section sizes	25
2.1.3	Vertical cross-section.....	25
2.2	Windows and passdoor.....	26
2.2.1	Number of windows.....	26
2.2.2	Windows.....	26
2.2.3	Passdoor low threshold.....	26
2.2.4	Passdoor standard threshold (180mm).....	27
2.3	Door operation	27
2.3.1	Selection guidelines for operation type.....	27
2.3.2	Selection guidelines for door operator	27
2.3.3	900 Door control systems - Selection guidelines.....	28
2.3.4	900 Door control systems - Selection guidelines for automation	28
3.	CEN Performance	30
3.1	Lifetime expectation	30
3.2	Resistance to windload	30
3.3	Resistance to water penetration.....	30
3.4	Air permeability	30
3.5	Thermal transmittance.....	31
3.6	Operating forces and safe openings.....	31
4.	Building and space requirements	32
4.1	Building preparations	32
4.1.1	Installation preparations.....	32
4.1.2	Deflection of door panels	32
4.1.3	Electrical preparations.....	32
4.2	Space requirements	33
4.2.1	Space requirements SL.....	34
4.2.2	Space requirements HL.....	35
4.2.3	Space requirements LL	36
4.2.4	Space requirements VL.....	37
4.2.5	Space requirements Door operators.....	38
5.	Service	39
	Index	40

1. Description

1.1 General

The Crawford 542 overhead sectional door is one of the most stable and well-insulated overhead doors on the market.

It is an overhead sectional door, suitable for all types of buildings, with regard to both function and appearance. High flexibility makes it possible to install this door in almost every type of building.

The door slides up under the roof when opened, allowing free space around the door opening and leaving the door opening completely free.

The door is made of insulated panels that provide minimal thermal transmittance, which reduces energy cost.

The Crawford 542 overhead sectional door has been designed to meet all operational and safety requirements in the European Directives and the standards issued by the European Standardization Committee, CEN.

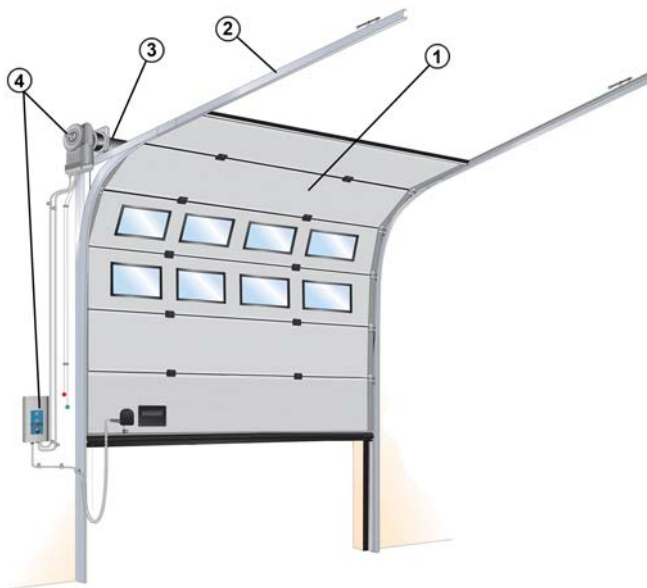

The door has 4 primary parts:

- 1 Door leaf
- 2) Track set
- 3) Balancing system
- 4) Operating system/chainhoist (optional)

1.1.1 Standard

Although every Crawford door is custom built, the Crawford 542 overhead sectional door is supplied with the following specifications as standard:

Door leaf:	Insulated steel or aluminium panel
Locks:	Lock bolt with lock hole protection
Colours:	9 RAL colours, pre-coated
Track type:	SL: Standard Lift
Operation:	Pull down rope and step/lifting handle
Safety:	SBD: Spring Break Device

1.1.2 Options

Crawford provides a wide range of options and accessories to customise the Crawford 542 overhead sectional door to any customer's needs.

Top panel:	Up to 900 mm
Passdoor:	In door leaf, Low threshold or Normal threshold
Panel windows:	DARP: Double glazed Acrylic Rectangular Pane DAOP: Double glazed Acrylic Oval Pane
Framed section:	242 door section
Locks:	Cylinder lock
Colours:	Factory painting - complete or panel only
Fixed sections:	Top and side sections
Track types:	HL: High Lift LL: Low Lift VL: Vertical Lift
Operation:	D hoist T hoist U hoist CDM9 Operator CDM9 HD Operator CDM9 2H Operator
Safety:	CBD: Cable Break Device
Anti corrosive hardware:	Powder coated end caps, tracks, hinges, connection beam, etc
Ventilation:	Ventilators

1.2 Door leaf

1.2.1 Construction

The Crawford 542 overhead sectional door leaf has horizontal sections, connected together with hinges. The outer hinges of each section have rollers that run in the tracks. The horizontal sections are insulated panels, filled with water blown CFC-free polyurethane.



1.2.2 Material

The surface of the door leaf panels is characterized by the microrilled steel or aluminium sheet. The door leaf panels (steel pre-coated) fulfill outdoor corrosion resistance category RC3 according to EN 10169.

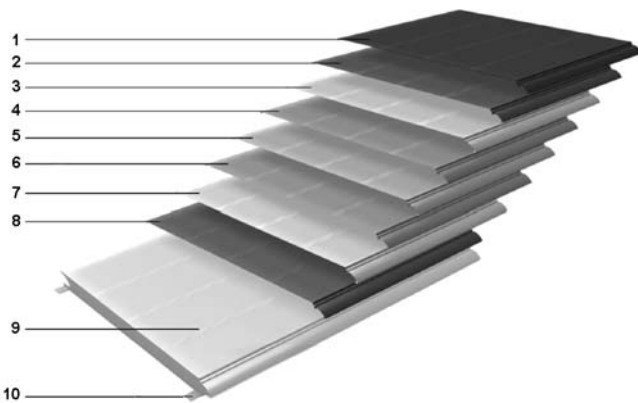

- 1 Polyester coating
- 2) Primer
- 3) Chromate layer
- 4) Zinc and Aluminium coating*
- 5) Steel or Aluminium sheet
- 6) Zinc and Aluminium coating*
- 7) Chromate layer
- 8) Primer
- 9) CFC-free polyurethane (water blown)
- 10) Reinforcement strips

*Steel door leaf only. The aluminium door leaf is not coated.

1.2.3 Colors

The RAL-colors are as close as possible to the official RAL HR collection. Max. deviation is 1,0 ΔE

Pre-coated range:



1.2.3.1 Pre-coated colors

Steel

- Outside color: The steel panel is available in the 9 standard colors.
- Inside color: RAL 9002 - Grey white.

Aluminium

- Outside colour: The aluminium panel is available in 2 standard colors: RAL 5010 - Gentian blue, RAL 9010 - Pure white.
- Inside color: Clear polyester.

1.2.3.2 Optional colours *

Factory painting

The door leaf can be factory painted in any RAL and NCS color plus some metallic colours, outside only. The painting can be applied to only the panel or to the complete door leaf, including frames and strips.

Panel only

Complete

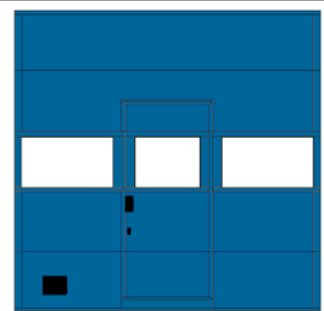
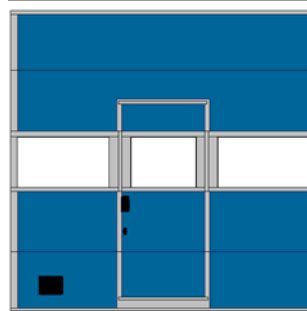

* Other colors available on request



1.2.4 Seals

The door is equipped with well designed sealings on all sides which gives the door its excellent sealing abilities.

1.2.4.1 Top seal

Installed on the top panel, to seal the gap between the panel and the wall. The flexible rubber material provides continuous pressure on the top wall, ensuring maximum sealing.



1.2.4.2 Side seal

Installed on the track set to close the gap between the tracks and the door leaf. The flexible rubber material provides continuous pressure on the door leaf, while dodging irregularities, ensuring maximum sealing.



1.2.4.3 Bottom seal

Installed on the bottom edge of the bottom panel, to act as a barrier as well as a shock absorber. The flexible rubber material and the O-shape provides continuous pressure on the floor, ensuring maximum sealing.

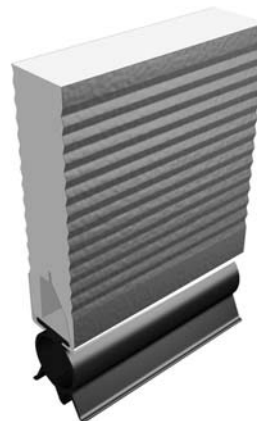

1.2.5 Wind reinforcement truss

Wider door panels and panels with windows are reinforced with metal profiles that act as trusses. These trusses reduce bending of the panel caused by wind loads or when the door leaf is in the horizontal position and is bending under its own weight.

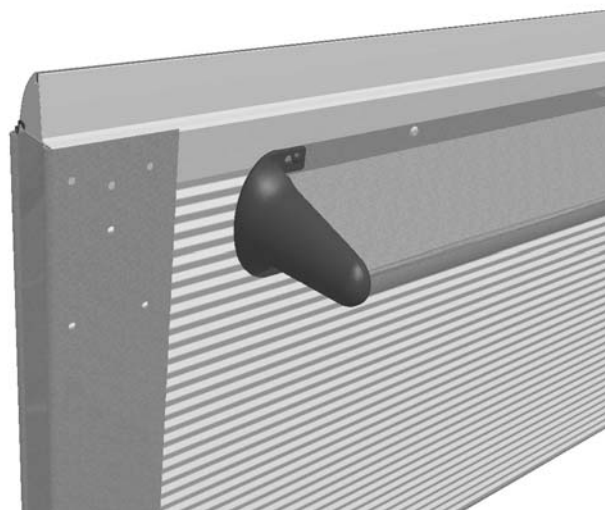

1.2.6 Handle

For manual operation, every Crawford 542 overhead sectional door is provided with a solid, easy to grip and step-on handle, finished with the Crawford logo.



1.2.7 Locks

1.2.7.1 Lock bolt

A standard Crawford 542 overhead sectional door is equipped with a Lock bolt.

The Lock bolt locks the door from the inside, without the use of a key.

The Lock bolt is not visible from the outside.

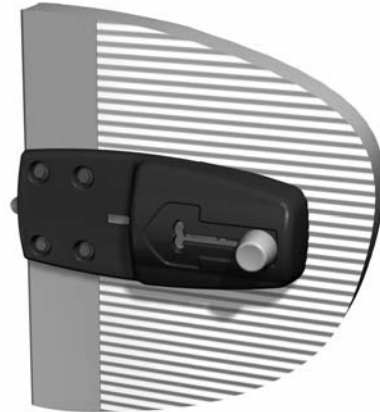

1.2.7.2 Cylinder lock

The Cylinder lock is a key operated lock which offers extra security. The lock is installed on the inside and can be unlocked with a key and turning the handle. Access to the Cylinder lock is possible from either only the inside, or both the inside and the outside.





1.2.8 Windows

The door sections can be glazed with windows*. The number of windows per section is directly related to the daylight width. Optionally, one single window can be placed on the outer left or right side, in the third section.

*The bottom section cannot be glazed.

1.2.8.3 Frame section

The Crawford 542 overhead sectional door can be fitted with a Crawford 242 frame section. The height of this section is 600mm. Please refer to Crawford 242 documentation for details.

1.2.8.1 DARP



- Double Acrylic (3 + 2 mm) Rectangular, in Plastic frame
- Light opening: 604 x 292 mm
- Window frame: Black

1.2.8.2 DAOP



- DAOP: Double Acrylic (3 + 2 mm) Oval, in Plastic frame
- Light opening: 610 x 292 mm
- Window frame: Black



1.2.9 Fixed sections

Fixed sections can advantageously fill space around new doors that are smaller than the wall opening. Fixed sections are available in top and side sections. Fixed sections are supplied in the same color and construction as the door leaf.

A fixed section can be provided with a passdoor for two reasons: Safety and energy cost reduction.

- Safety: Putting a separate passdoor in a fixed section next to the industrial door separates pedestrian and vehicle traffic.
- Energy cost reduction: The opening space for frequent pedestrian traffic is minimized.

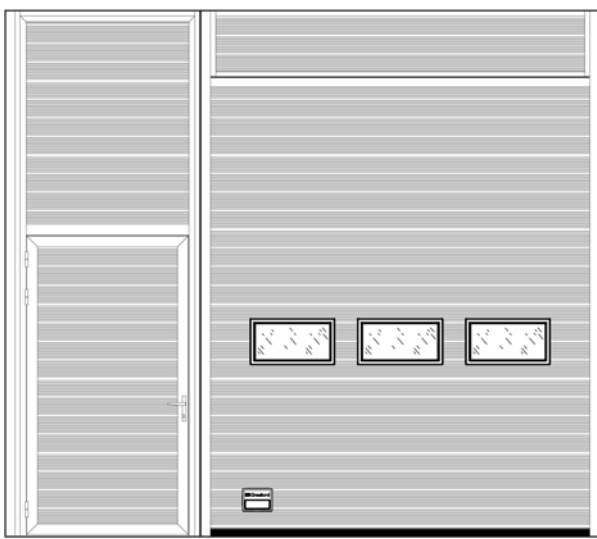



1.2.10 Passdoor with low threshold

The passdoor with low threshold is designed to optimise comfortable pedestrian passing and minimises the risk of tripping. In addition, with the sturdy design of the bottom profile it is not required to strengthen the door leaf with a bottom reinforcement truss. The passdoor is designed with a push/pull grip which ensures an easy and simple opening and closing of the passdoor.



Construction

This passdoor is designed with a 542 bottom section with a sturdy and wide aluminium profile. This profile is ribbed, minimising the risk of slipping when there is rain or snow on the floor or on the profile. (D = Market dependent)

At passdoor

Beside passdoor

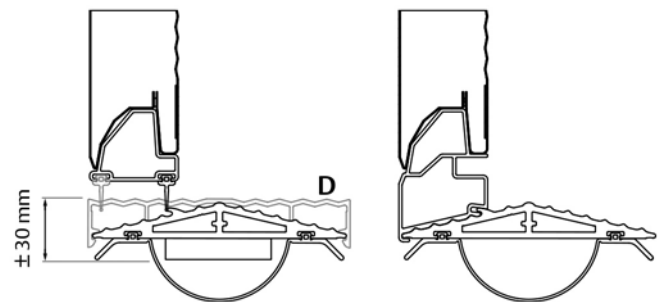

Outside view of threshold



Types of operation

The low threshold passdoor is available for all types of operation. In case of impulse-down button operation, a special CDM9 with 950 control unit is required with a light curtain in the tracks that detect persons or objects in the door opening when the door closes.

Features:

- Always opening outwards, min. 90 degrees opening
- Hinged left or right
- Seals in passdoor frame reduce air permeability.
- Integrated passdoor switch if electrically operated
- Ring shaped door handle
- All commonly used cylinder locks are available:
Euro, Kaba, Assa-Abloy. Standard : Euro cylinder lock
- Door closer type M.A.B.
- Panic lock NEMEF/CISA (option).

1.2.11 Passdoor with standard threshold (180 mm)

The standard 180 mm is designed to be combined with virtually all options of the door. It is not applicable as an emergency exit, with a threshold of 180 mm. The passdoor is designed with a push/pull grip which ensures an easy and simple opening and closing of the passdoor.

Construction

This passdoor is constructed with the standard bottom section and bottom seal. A reinforcement truss on the bottom section is required to maintain the door's sturdiness and resistance to wind load.



At passdoor

Beside passdoor

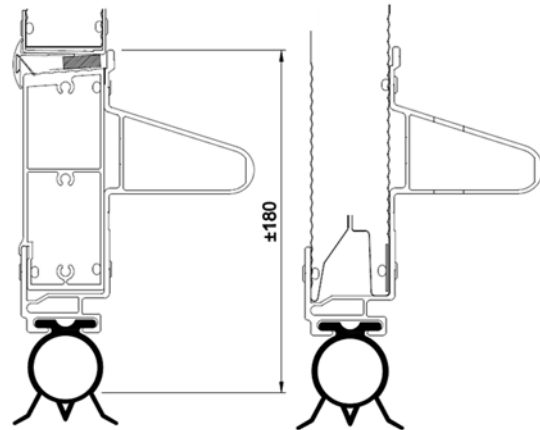

Outside view of threshold

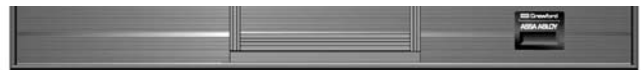

Features:

- Always opening outwards, min. 90 degrees opening
- Hinged left or right
- Seals in passdoor frame reduce air permeability.
- Integrated passdoor switch if electrically operated
- Ring shaped door handle
- All commonly used cylinder locks are available:
Euro, Kaba, Assa-Abloy. Standard : Euro cylinder lock
- Door closer type M.A.B.
- Panic lock NEMEF/CISA (option).



1.3 Track sets

1.3.1 General

The track set supports the door leaf on its rollers and guides it upwards. The selection of the appropriate track set is based on various factors:

- Available head room
- Door height
- Type of vehicles
- Presence of roof obstructions, pipes and overhead crane beams.

The track sets below cover most applications. Other applications are available on request.

1.3.2 Standard lift

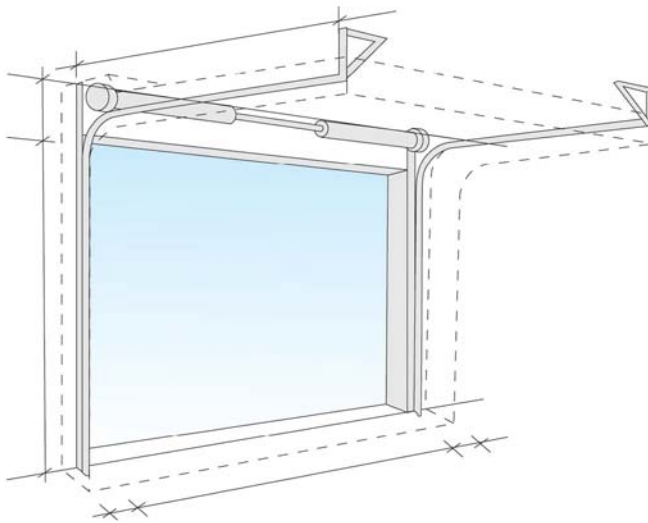

- Building type: Most standard industrial buildings.
- Benefits: Optimal design for common buildings.

The Standard Lift track set, with the spring package just above the door, is the most common solution

1.3.3 Standard lift low

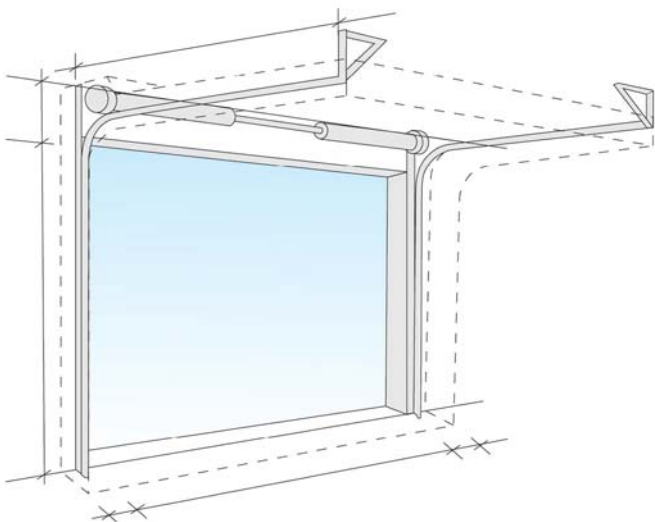

- Building type: Low ceilings.
- Benefits: Achieve more daylight width with a limited head room.

The Standard Lift Low track set is a variant of the Low Lift where the spring package is installed just above the door.

1.3.4 High lift

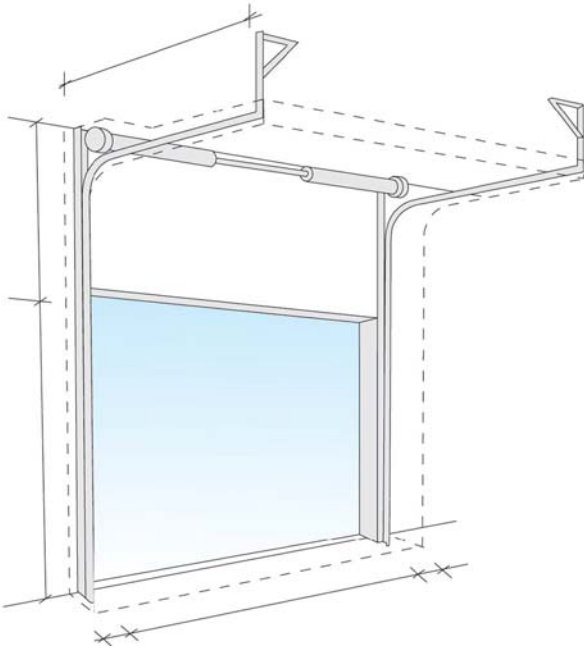

- Building type: High ceilings. On the High Lift track set the spring package is placed high above the door.
- Benefits: This track type allows high vehicles to cross along the door opening without obstructions of the horizontal tracks.

This track type is used when the space above the door is considerable, and is needed for work and traffic, e.g.: high vehicles.

1.3.5 Low lift

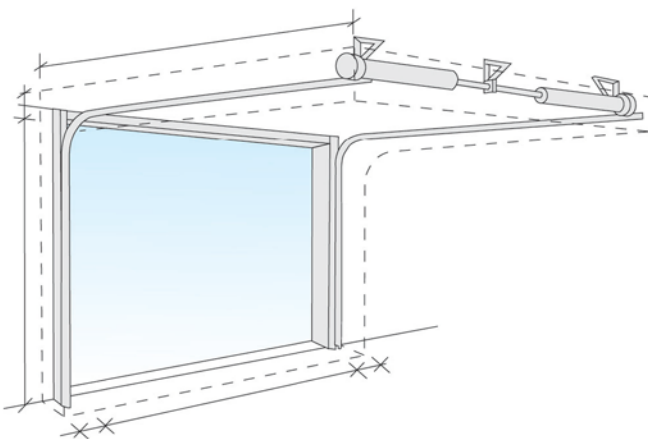

- Building type: Low ceilings.
- Benefits: Achieve maximum daylight height with minimum head room

Same as standard lift, but with the spring package at the end of the horizontal tracks. The space between the door opening and the roof does not need to be more than 265 mm.

For doors with a weight > 250 kg and/or doors with pass door, the required head room is 300 mm.

1.3.6 Vertical lift

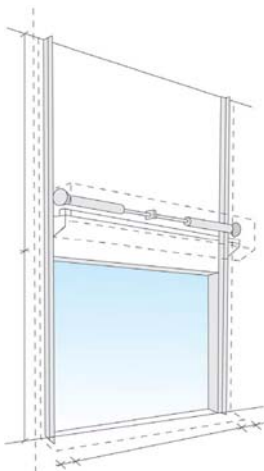

- Building type: Very high ceiling and high working space requirements.
- Benefits: Allows high vehicles to cross along the door opening without any obstructions.

If the space between the daylight height and the roof is sufficient, with this track type, the door can be opened vertically.



1.3.7 Special track sets

The Crawford 542 overhead sectional door track set can be custom designed to make the door fit in places that seem quite impossible. Our door technicians can solve installation problems where the door must share space with ventilation systems, crane beams, etc. For example:

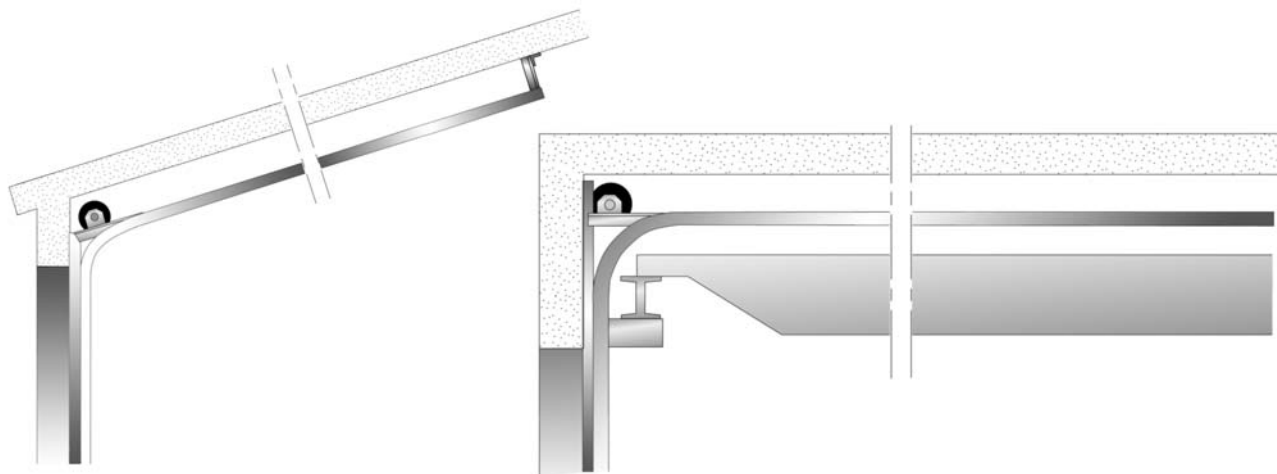

1.4 Balancing system

The balancing system balances the door by applying a force nearly equal to the weight of the door leaf. This allows the door leaf to be moved up and down manually, and to stay open in any position.

The system is installed on the top or the end of the track set and works as follows: Two torsion springs are installed on a shaft above the door opening. This shaft has a cable drum on each end from which door cables run to the bottom corners of the door leaf. Turning the shaft lifts the door up or down.

1.4.1 Safety devices

The balancing system supports heavy forces. In case of a spring or cable break, its counterforce is lost. The door is therefore equipped with two safety devices that can block downward door movement:

- Spring Break Device (standard)
- Cable Break Device (optional)

1.4.1.1 Spring break device (SBD)

The Spring Break Device (SBD) is delivered with all Crawford 542 overhead sectional doors.

In the event of a spring break, the sudden drop force activates the Spring Break Device (SBD). The shaft will be locked in less than 300mm of door movement.



1.4.1.2 Cable break device (CBD)

The Cable Break Device (CBD) is an optional safety device. In the event of a spring failure in the door balancing system the door leaf will be brought to rest after a drop of less than 300mm.





1.5 Operating system

1.5.1 Types of operation

The Crawford 542 overhead sectional door can be opened and closed manually. They are also prepared for electrical operation. Electrically operated doors can be controlled by hand or be fully automatic. Traffic frequency, climate requirements and the weight of the door play a key role in choosing the optimal control system.

1.5.1.1 Pull-down rope

The Crawford 542 overhead sectional door can be operated manually with a pull-down rope. The pull-down rope is directly connected to the door leaf.



1.5.1.2 Chain hoist

For heavier doors, a chain hoist allows easier door operation. There are three types of chain hoist:

- D-hoist: Non-g geared chain transmission directly connected to the shaft. Recommended for doors up to 250 kg (For hexagonal shaft only).
- T-hoist: Geared (ratio 1:4) chain transmission directly connected to the shaft. Recommended for doors up to 250 kg (For all shaft types).
- U-hoist: Geared (ratio 1:3) indirect chain transmission. Recommended for doors of 250 kg and above (For all shaft types).

D-hoist:



T-hoist:

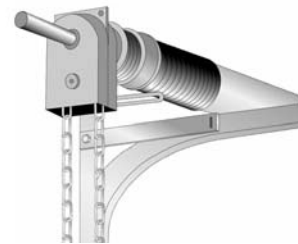

U-hoist:



1.5.1.3 Electrical operation

The Crawford 542 overhead sectional door can be supplied or upgraded with an electrical operating system. Electrical operation gives access to the full program of Access and Automation functions, that can fulfill many operational needs, related to traffic type and frequency, door weight and temperature control.



1.5.2 CDM9 Operator - 900 Door control systems

The CDM9 operator is a combination of the CDM9 operator and a 900-series Door control system. The regular CDM9 model is available for doors up to 400 kg. The CDM9 HD model is available for doors up to 650 kg. The double speed CDM9 2H model is available for doors up to 250 kg.

1.5.2.1 CDM9 Operator

One main part of the system is the operator: an electric motor which drives the balancing shaft with the cable drums and torsion springs. It can be retrofitted to an already installed door. The CDM9 operator is mounted directly on the balancing shaft and does not require any special wall reinforcement.

Key features:

- Smooth and silent
- Soft start and stop
- Fits all track types and shafts
- Life time: 84.000 - 300.000 door cycles (depending on weight and temp.) e.g.:
 - temp. 0 °C - +40 °C/weight 250 kg = 300.000 cycles
 - temp. -20 °C - +60 °C/weight 400 kg = 84.000 cycles





1.5.2.2 900 Door control systems

General

The 900 Door control system series provides a range of control units, from basic up, stop and down buttons to advanced automated control.

The design of all control units is based on modules, and it is possible to upgrade or downgrade safety or automation functions. Additional kits such as magnetic loop, photocells, radar, radio and reduced door opening are available.

920 Door control system

The 920 Door control system is the basic control unit that has the necessary hold-to-run or impulse open, hold-to-run close and stop functions and a slot for an external control box.

This control unit is the economical solution for working environments where the door opening frequency is low.



950 Door control system

The 950 Door control system is the most advanced control unit that is prepared for one or more physical upgrades from the entire range of automation systems. An automation system allows door operation by sensors or remote control.

This control unit contains a 3-digit diagnostics display that allows efficient troubleshooting and displays the number of door cycles. Together with the service indicator, this extra feature allows advanced maintenance planning to users where the door is an essential element of internal logistics.



930 Door control system

The 930 Door control system is a basic control unit that has impulse up and down functions with supervised safety edge. An extra set of upgrade features, such as external control, that can be installed during or after installation, is available.

This control unit is the more advanced solution for door openings that are frequently used by pedestrians and forklift trucks, because of its automated opening and closing function.



1.5.3 Access and automation

Crawford offers a wide range of functions that allows advanced opening and safety control. Please refer to the specification sheet of the control units to see which functions apply to which models.

1.5.3.1 Basic control functions

Interlocking



Developed for climate control or safety; If door A is open, door B cannot be opened. If door B is open, door A cannot be opened. An interlocked door can remember an up-command, if selected via a micro switch.

Reduced opening

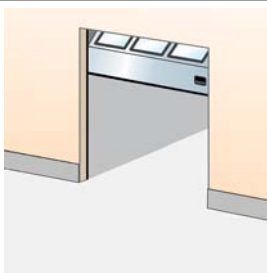

When it is unnecessary or undesirable to fully open a door, an additional switch can be used to open the door to a pre-programmed reduced opening position.

1.5.3.2 External control functions

External push button box

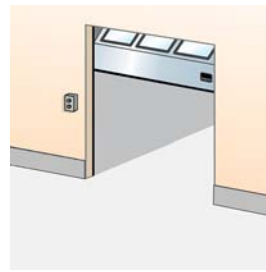

An extra control box is installed outside the building or inside close to the door if the main control unit needs to be installed away from the door opening. Installed on the inside or outside wall beside the door.

Pull-rope switch

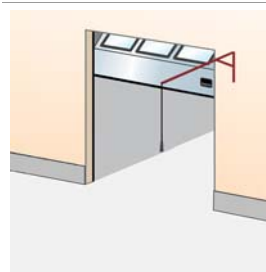

A pull-rope switch above the door opening can be operated from e.g. a forklift truck. Pulling the rope opens a closed door or closes an opened door. Installed on the inside construction above the door.

Remote control



A hand-held radio transmitter allows door operation from a vehicle or any position within 50-100 meters from the receiver and aerial at the door. For closing, the door can be provided with a photocell beam. Receiver installed in control unit, antenna installed on the wall beside the door.



1.5.3.3 Automatic control functions

Magnetic loop

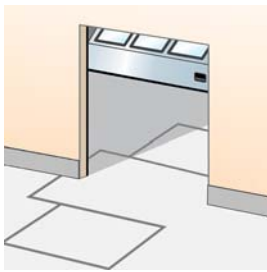

A sensor in the floor detects a metal object (usually forklift trucks, pallet trucks) and opens the door automatically. This is an ideal solution for frequent vehicle traffic.
Installed on the outside, inside or both sides of the door in the floor.

Radar

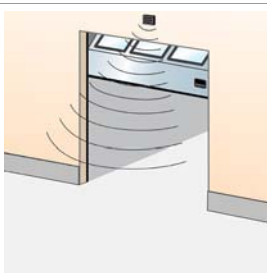

An infrared sensor above the door detects an object (person, vehicle) within a specified distance from the door and opens the door automatically. This is an ideal solution for frequent vehicle or personal traffic. Often combined with automatic closing.
Installed on the inside or outside wall above the door.

Photocell open door

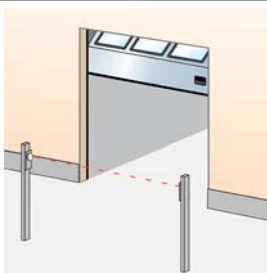

A set of photocells on pillars, on each side of the door. When a person or vehicle passes between the photocells, the beam is interrupted and the door opens. Photocells installed on pillars, away from the door.

Automatic closing

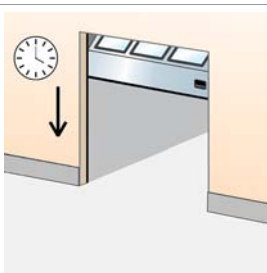

A programmable timer that closes the door after a specified time, counted from either the fully open position and/or from passing through the photocell beam. Adjustable micro switches in control unit.

1.5.3.4 Safety functions

Safety edge

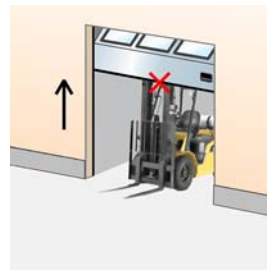

As a standard, all doors that have the impulse-close function or any form of automated closing, are equipped with a safety edge. The pneumatic sensor in the bottom seal detects any obstruction under a closing door and reverses the door.
Installed in the bottom seal.

Safety photocells 1-channel

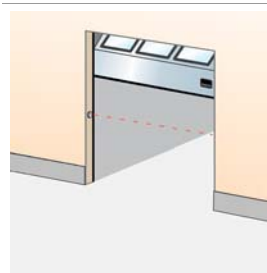

A set of a photocell transmitter and receiver is installed in the door opening. If the photocell beam is interrupted during closing, the door will stop in less than 30mm and reverse to the fully open position.
Installed in the door opening.

Safety photocells 2-channel

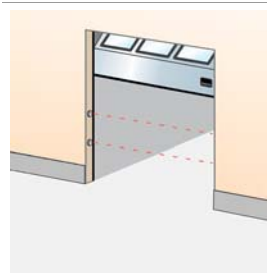

Two sets of photocell transmitter and receiver are installed in the door opening. If one or both photocell beams are interrupted during closing, the door will stop in less than 30mm and reverse to the fully open position.
Installed in the door opening.

Warning lights - Red

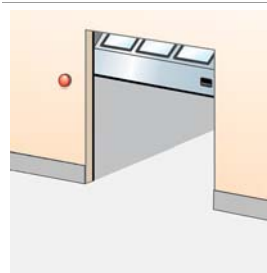

Two red warning lights giving information on the current door behaviour. Flashing light before or during door movement. Optional: Continuous light before and during door movement.
Installed on the inside and outside wall beside the door.

Warning lights - Green

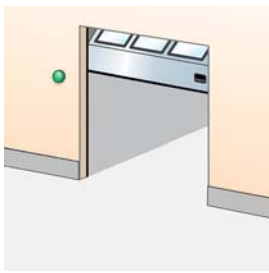

One or two green warning lights indicating the open position of the door by continuous light signal.
Installed on the inside and/or outside wall beside the door.

Traffic lights - Red & Green

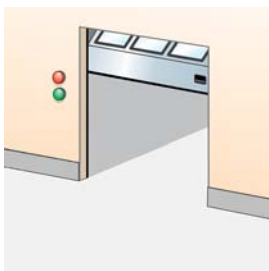

If traffic through a door needs to be directed; two red and two green traffic lights can be installed to indicate traffic direction. From the side where a vehicle is first detected to approach the door, the green traffic light comes on. The opposing side shows a red traffic light. Traffic from this direction must give way to the other. Usually installed in e.g. parking garages.
Installed on the inside and outside wall beside the door.

1.5.3.5 Additional functions

UPS battery backup



When mains failure cannot be permitted or an increased risk of mains failure is predicted, the UPS battery backup system can be installed to store enough energy for 10 door cycles.
Installed on the inside wall beside the door.

Relay box



A sealed connection box makes it possible to safely connect external high-voltage equipment.



1.6 Monitoring systems

As an option on all our products, a Crawford Monitoring System can be installed. This system helps to ensure efficiency and security in daily operations. All doors or docking stations are connected to the Monitoring System's server, which gives the opportunity to supervise, monitor and report a wide variety of aspects in a facility.



1.6.1 Saving energy

A monitoring system reduces energy costs and contributes to a better environment. Energy is lost every time a door is open. If a door is open when no truck is at the bay, even more energy is lost.

A Crawford Monitoring System automatically ensures that no door will open unless there is a truck at the bay and even set it to close when there an activity is delayed.

1.6.2 Security enhancement

Closing and locking doors is an obvious daily routine. However, checking this manually can be time consuming in a busy facility.

A Crawford Monitoring System can automatically ensure that all doors are closed and locked when they need to be. It can also activate all doors and locks from its remote location, and give a real-time overview of the building's situation.

1.6.3 Dock management

A good way to increase throughput and thereby efficiency at a logistics facility is to reduce the time of having no truck – or the wrong truck – at a loading bay.

A Crawford Monitoring System makes visible – in real-time – which bays are occupied or free, and for how long. It makes it possible to reserve bays for docking activities and to inform drivers via SMS. Since it incorporates information from cameras and other inputs (RFID, card readers, etc.), the system stays updated in real-time.

1.6.4 Facility management

The Crawford Monitoring System gives a real-time service status for all your door and docking equipment. If an error code occurs, the Crawford service organisation is automatically notified, and will respond quickly. Other maintenance information can easily be integrated, further reducing the overall costs.

2. Specifications

2.1 Dimensions

2.1.1 Daylight width and daylight height

The standard Crawford 542 overhead sectional door is delivered in the following size range:

	Daylight width	Daylight height
Min.:	2050 mm	2150 mm
Max.:	8000 mm	6000 mm

On request available up to 10000 x 6000 mm.

2.1.2 Section sizes

Section height:	600 mm
Top section height:	300-900 mm trimcut
Thickness:	42 mm

The door leaf height is achieved by trimcutting the top section.

2.1.3 Vertical cross-section

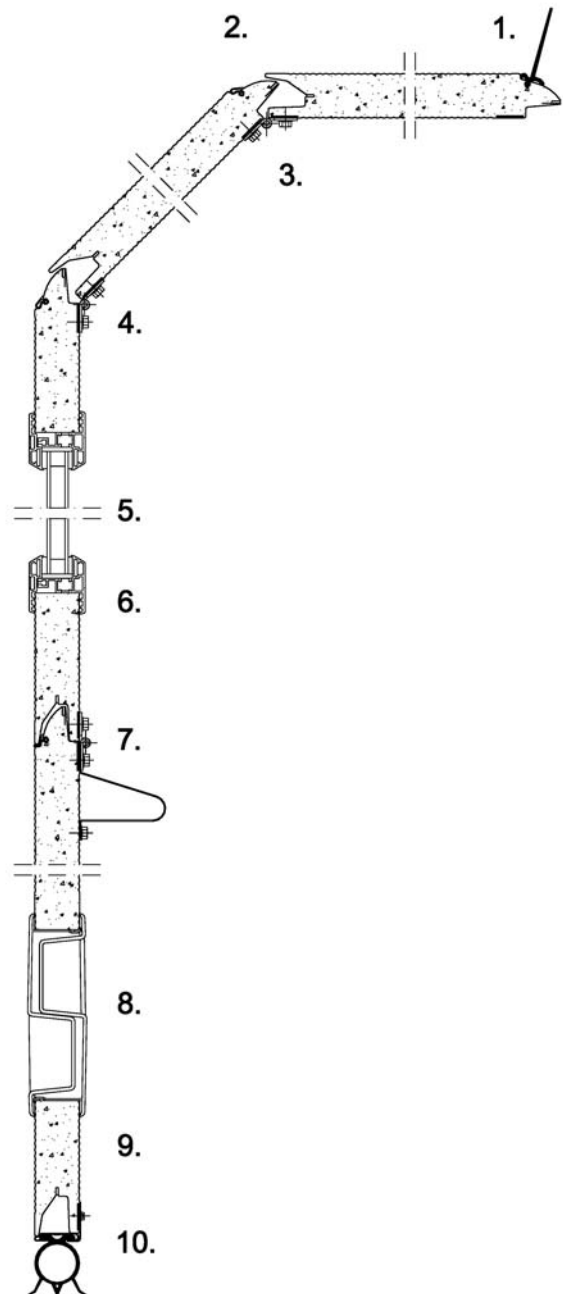

- 1 Top seal
- 2) Section joint with finger pinch protection and seals
- 3) Inner and outer sheet
- 4) Internal steel reinforcement, to provide positive fixing points
- 5) Window (optional)
- 6) High impact polystyrene frame
- 7) Panel truss - wind reinforcement (if necessary)
- 8) Step/lift handle
- 9) Insulation (CFC-free / water blown)
- 10) Bottom seal



2.2 Windows and passdoor

2.2.1 Number of windows

For windows and passdoors, the daylight width is divided into a fixed grid. The number of windows depends on the daylight width of the door.

542 Windows

Daylight width	No. of windows
2050 - 2134 mm	1
2135 - 2999 mm	2
3000 - 3864 mm	3
3865 - 4729 mm	4
4730 - 5594 mm	5
5595 - 6050 mm	6

Optional: One window in the outer left or right side of section 3 only.

242 Windows

Daylight width	No. of windows
2050 - 3050 mm	2
3051 - 4550 mm	3
4551 - 6050 mm	4
6051 - 7250 mm	5
7251 - 8000 mm	6

2.2.2 Windows

DARP

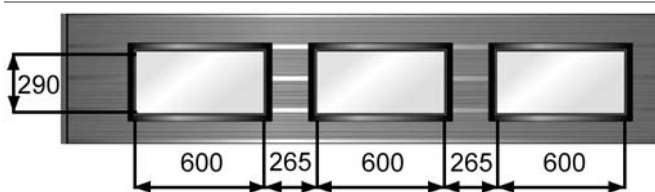

DAOP



2.2.3 Passdoor low threshold

Passdoor opening sizes

Width:	810 mm
Height from floor level:	2050 mm

Position of passdoor

Daylight width	Window no.
2050 - 2134 mm	1
2135 - 2999 mm	1 or 2
3000 - 3864 mm	2
3865 - 4729 mm	2 or 3
4730 - 5500 mm	2, 3 or 4

* In case 242 section(s) are included, a passdoor is not possible in the outer panes for construction reasons.

Permissible overhead door sizes

Minimum permissible DLW	2050 mm	
Maximum permissible DLW	5500 mm	
Minimum permissible DLH (if operated manually or with hold-to-run down button)	2215 mm	
Minimum permissible DLH (if operated with impulse down button)	Standard Lift	≥ 2620 mm
	High Lift (DLH+HL)	≥ 2800 mm
	Low Lift (CLH)	≥ 2705 mm
	Vertical Lift	No limit
Maximum permissible DLH	6050 mm	

Other limitations

- If the door is electrically operated with impulse-close or automatic closing, a specific CDM9 with 950 operator is required in combination with a light curtain in the tracks.
- Only possible with a 542 bottom section.

Specifications

Threshold height:	30 mm incl. bottom seal
Lock:	Depends on market
Door closer:	MAB or equal

2.2.4 Passdoor standard threshold (180mm)

Passdoor opening sizes

Width:	810 mm
Height from floor level:	2050 mm

Position of passdoor

Daylight width	Window no.
2050 - 2134 mm	1
2135 - 2999 mm	1 or 2
3000 - 3864 mm	1, 2 or 3
3865 - 4729 mm	1, 2, 3 or 4
4730 - 5594 mm	1, 2, 3, 4 or 5
5595 - 6050 mm	3 or 4

* In case 242 section(s) are included, a passdoor is not possible in the outer panes for construction reasons.

Permissible overhead door sizes

Minimum permissible DLW	2050 mm
Maximum permissible DLW	6050 mm

Minimum permissible DLH	2215 mm
Maximum permissible DLH	6050 mm

Specifications

Threshold height:	180 mm incl. bottom seal
Lock:	Depends on market
Door closer:	MAB or equal

2.3 Door operation

2.3.1 Selection guidelines for operation type

Door size m ²	Openings / day			
	1-5/day	5-10/day	10-15/day	>25/day
0 - 10	□ / ■	□ / ■	■ / ■	■ / ■
10 - 20	□ / ■	■	■ / ■	■ / ■
> 20 - 42	■	■	■ / ■	■ / ■
> 42*	■	■	■ / ■	■ / ■

□ Manual operation

■ Electrical operation

■ Automated operation

2.3.2 Selection guidelines for door operator

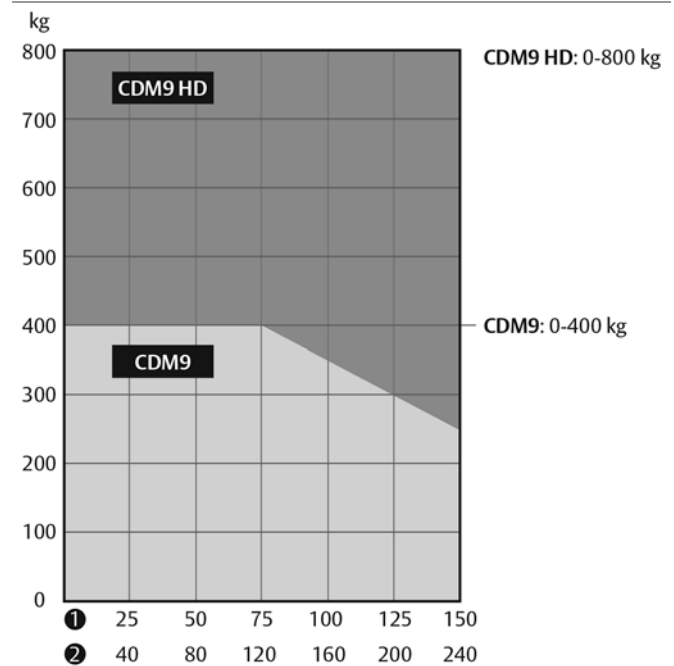

Door openings/day



- Over 300 days/year
- Over 220 days/year

Average door weight

Steel door : 13 kg/m²
Alu door : 10 kg/m²



2.3.3 900 Door control systems - Selection guidelines

Functions included	920	930	950
			
Open (by impulse)	■	■	■
Open (hold to run)			
Stop	■	■	■
Close (by impulse)		■	■
Close (hold to run)	■		
Safety edge		■	■
Open function		■	■
One button function			■
Display (diagnostics)			■
Service indicator			■

- Standard
- Option / Available



2.3.4 900 Door control systems - Selection guidelines for automation

The “Automation D-kits” are packages of common combinations. These kits can also be supplemented by “additions to D-kits”.

Automation D-kits	D1	D2	D3	D4	D5	D6	D7
Interlocking	■	■	■	■	■	■	■
Magnetic loop		■		■		■	
Traffic lights - Green + Red					■	■	
Warning lights - Red	■			■			
Additions to D-kits							
Warning lights - Green			□				
Relay box	□	□	□	□	□	□	□
Radar	□	□	□	□	□	□	□

- Standard
- Option / Available

The following options can be individually selected to add functionality to the control unit.

Functions optional	920	930	950
			

Complete kits			
Automation D-kits			<input type="checkbox"/>
Basic control functions			
Interlocking			<input type="checkbox"/>
Reduced opening			<input type="checkbox"/>
External control functions			
External pushb. box	<input type="checkbox"/>	<input type="checkbox"/>	<input type="checkbox"/>
Pull-rope switch		<input type="checkbox"/>	<input type="checkbox"/>
Remote control open/stop/close		<input type="checkbox"/>	<input type="checkbox"/>
Remote control 1-button function			<input type="checkbox"/>
Automatic control functions			
Automatic closing		<input type="checkbox"/>	<input type="checkbox"/>
Photocell open door			<input type="checkbox"/>
Safety functions			
Safety photocell (1 or 2)		<input type="checkbox"/>	<input type="checkbox"/>
French safety logic			<input type="checkbox"/>
Additional functions			
UPS Battery backup	<input type="checkbox"/>	<input type="checkbox"/>	<input type="checkbox"/>
Relay box			<input type="checkbox"/>

Standard

Option / Available



3. CEN Performance

The following tests have been carried out by SP in Borås, Sweden and IFT in Rosenheim, Germany.

3.1 Lifetime expectation

- 100.000 door cycles or 10 years (in a normal industrial environment)
- Springs: 20.000 door cycles

3.2 Resistance to windload

EN12424	Without passdoor	With passdoor
Test result	Class 3	Class 3

Class	Pressure Pa (N/m ²)	Specification
0	-	No performance determined
1	300	
2	450	
3	700	
4	1000	
5	> 1000	Exceptional : Agreement between manufacturer and supplier

Door size 4000 x 3450 mm

3.3 Resistance to water penetration

EN12425	Without passdoor	With passdoor
Test result	Class 3	Class 3*

Class	Pressure Pa (N/m ²)	Specification
0	-	No performance determined
1	30	Waterspray for 15 minutes
2	50	Waterspray for 20 minutes
3	> 50	Exceptional : Agreement between manufacturer and supplier

* Danish Technological Institute (ref. 23413221, dated 24/09/2002)

3.4 Air permeability

EN12426	Without passdoor	With passdoor
Test result	Class 2 (6,6 m ³ /m ² /h)	Class 2 (6,6 m ³ /m ² /h)

Class	Air permeability dp at a pressure of 50 Pa (m ³ /m ² /h)
0	-
1	24
2	12
3	6
4	3
5	1,5
6	Exceptional : Agreement between manufacturer and supplier



3.5 Thermal transmittance

EN12428	Steel	Aluminium
Thermal transmittance *	0,96 W/(m ² .k)	1,14 W/(m ² .k)

* Door surface 5.000 x 5.000 mm (for other sizes it can differ)

3.6 Operating forces and safe openings

EN12453 & EN12604	Crushing force N	Crushing force N	Crushing force N
Opening gap mm	200 mm from lateral border right from outside	In the middle of the door opening	200 mm from lateral border left from outside
50 mm	passed	passed	passed
300 mm	passed	passed	passed

The crushing force is the force needed for the safety edge to be activated. The maximum force allowed, according to EN12453 safety in use of power operated doors is 400 N within a maximum period of time of 0.75s.

4. Building and space requirements

4.1 Building preparations

4.1.1 Installation preparations

The Crawford 542 overhead sectional door is shipped in parts and installed on-site. All necessary installation material is included. For every track type Crawford offers specific installation kits to position the door in the building facade.

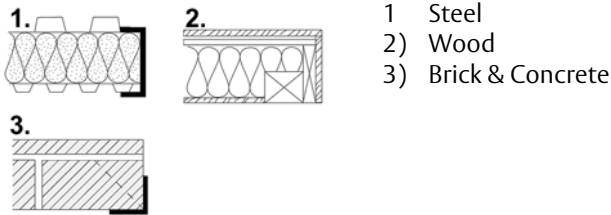

- 1) Steel
- 2) Wood
- 3) Brick & Concrete

4.1.2 Deflection of door panels

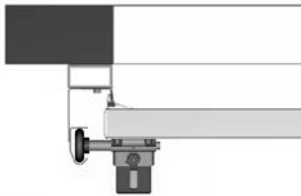

The following doors must be installed on a frame, equipped with an A-65 top seal.

- Doors DLW > 6000 mm
- Doors DLW > 4000 mm with high lift and dark outside colour, installed facing south.

4.1.3 Electrical preparations

The manually operated door needs no electrical supply.

For an electrically operated door, the following environment criteria and electrical supplies are required for the operator to function properly:

	CDM9	CDM9 HD	CDM9 2H
Voltage supply: +/- 10%	230V AC 1-phase 50/60Hz	230V AC 1-phase 50/60Hz	230V AC 1-phase 50/60Hz
Power:	0,37 kW	0,6 kW	0,37 kW
Degree of protection:	IP55, excl. connector IP 44	IP55, excl. connector IP 44	IP55, excl. connector IP 44
Allowed door weight, max.:	400 kg	650 kg	250 kg
Temperature working range:	-20 °C to +55 °C*	-20 °C to +55 °C*	-20 °C to +55 °C*
Operating factor:	ED = 30% S3 10 min. intermittent	ED = 30% S3 10 min. intermittent	ED = 30% S3 10 min. intermittent
Mounting preparations:	-	When installing to the wall, an extra attachment angle is required	-

*) Normal opening speed in a temperature down to -8°C. In the temperature range -8 °C to -20 °C the opening speed is reduced during the first cycle to prolong the operator's lifetime. An optional heating element is available for a working range down to -30 °C

4.2 Space requirements

DLH	= Daylight Height	The height of the clear opening
DLW	= Daylight Width	The width of the clear opening
D	= Depth	The space between the inner side of the wall and the end of the horizontal track construction
h	= Excess height	The extra space required above the daylight height.
SL	= Side space Left	The space required for tracks beside the daylight width.
SR	= Side space Right	The space required for tracks beside the daylight width.

The grey marked area in the illustrations shows the free space required by door movement. Extra space requirements for electrically operated doors are stated in the operator specifications. Extra space requirements for passdoors are stated in the passdoor specifications.



4.2.1 Space requirements SL

DLW	≤ 8000 mm
DLH	≤ 6000 mm
h	485 mm (if DLH ≤ 4500 mm) 510 mm (if DLH > 4500 mm)
SL/SR*	100 mm
D	DLH + 600 mm

* In case of an electrically operated door, SL or SR = 130 mm on side of safety pull.

Side view

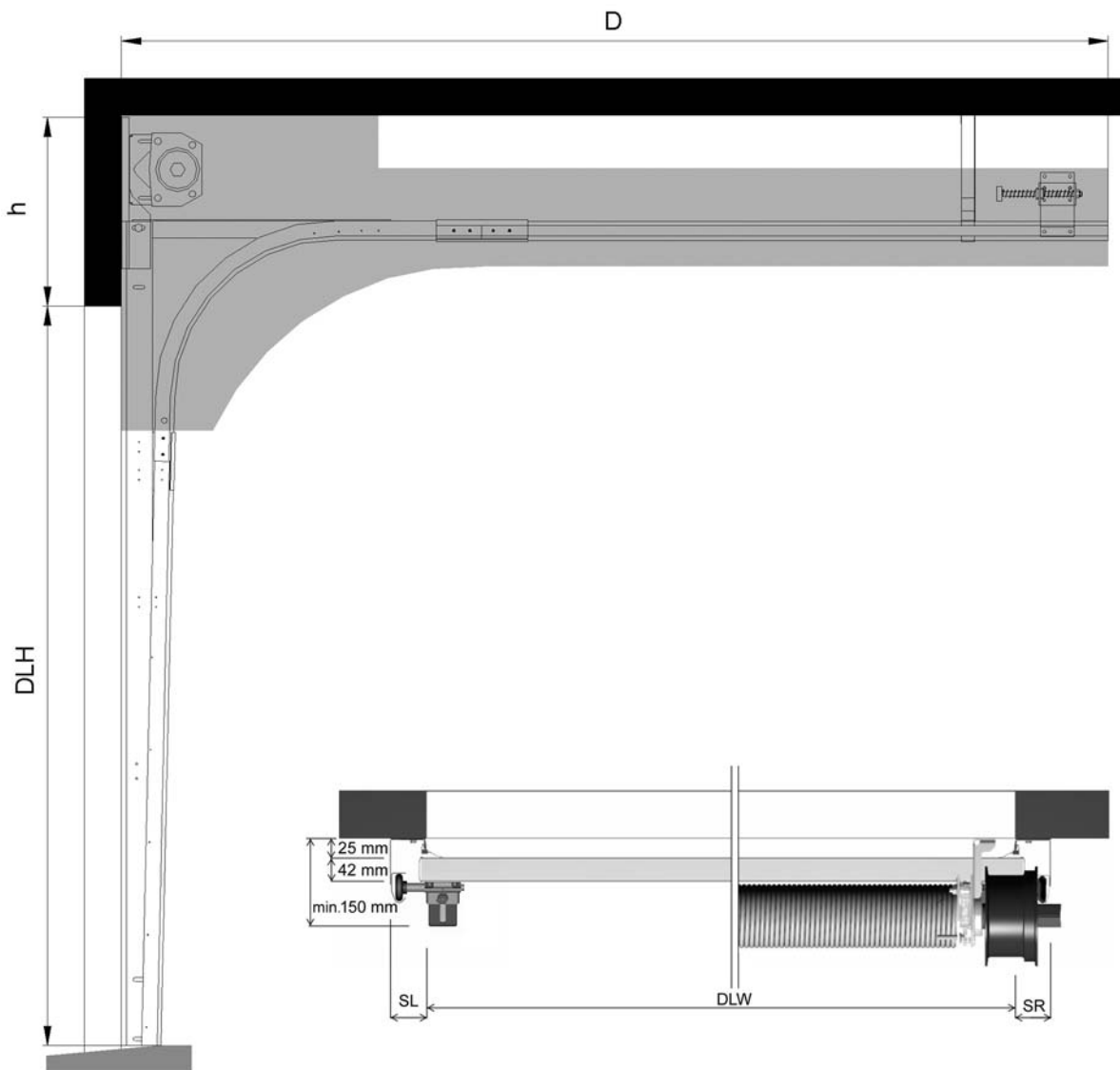

Top view

4.2.2 Space requirements HL

DLW*	≤ 8000 mm
DLH	≤ 6000 mm
h	HL+320 mm (if HL ≤ 3400 mm) HL+370 mm (if HL > 3400 mm)
SL/SR**	100 mm
D	DLH - HL + 800 mm

* The following doors must be installed on a frame, equipped with an A-65 top seal.

- Doors DLW > 6000 mm
- Doors DLW > 4000 mm with a dark outside colour, installed facing south.

** In case of an electrically operated door with safety pull, SL or SR = 130 mm on side of safety pull.

Side view

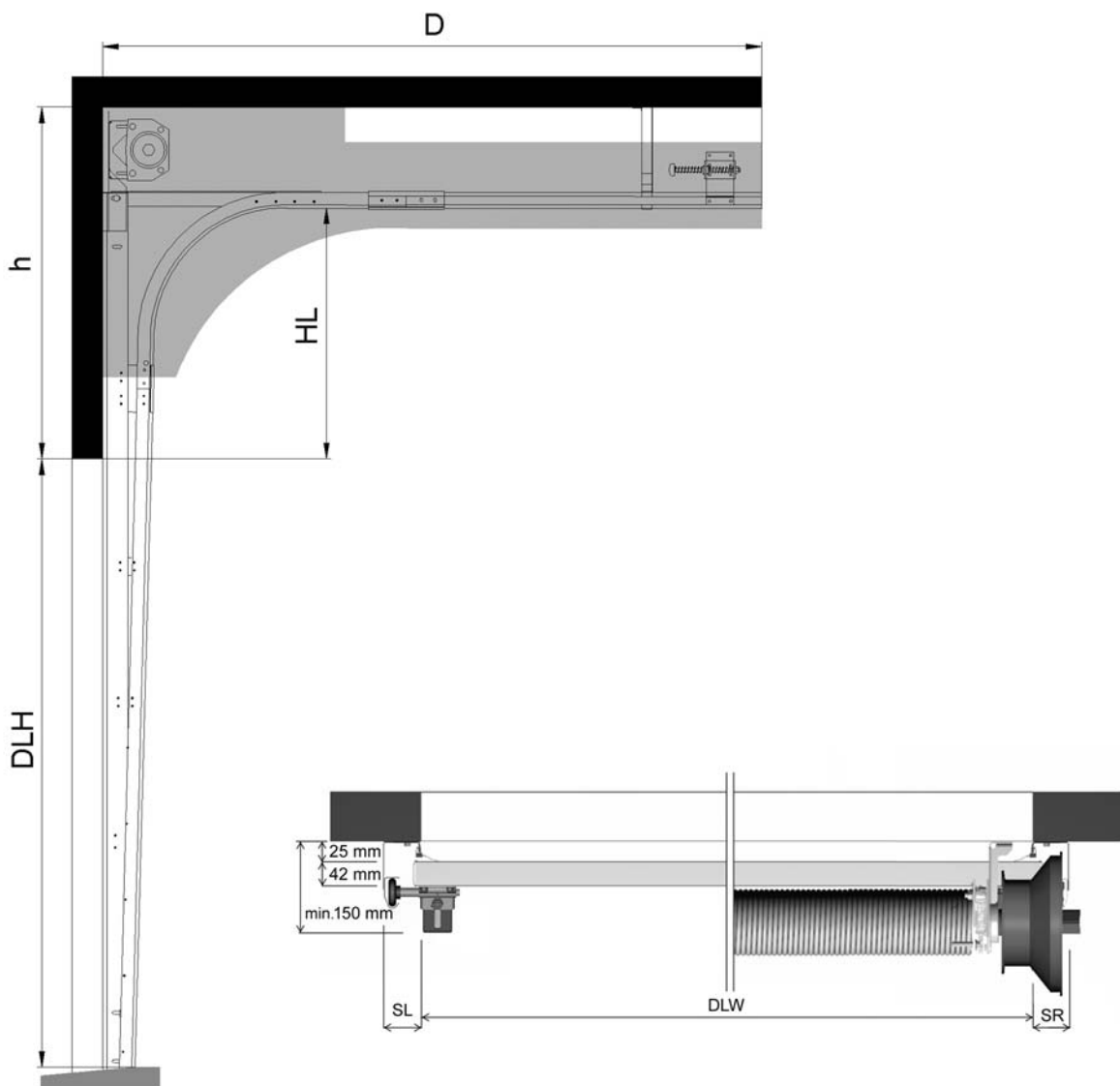

Top view



4.2.3 Space requirements LL

DLW	≤ 8000 mm
DLH	≤ 6000 mm
h*	265 mm (if ≤ 250 kg) 300 mm (if > 250 kg or passdoor)
SL/SR**	100 mm
D	DLH + 1100 mm

*If the door weight exceeds 250 kg and/or if passdoor is installed: h=300 mm

** In case of an electrically operated door, SL and SR = 130 mm (because of safety pulls).

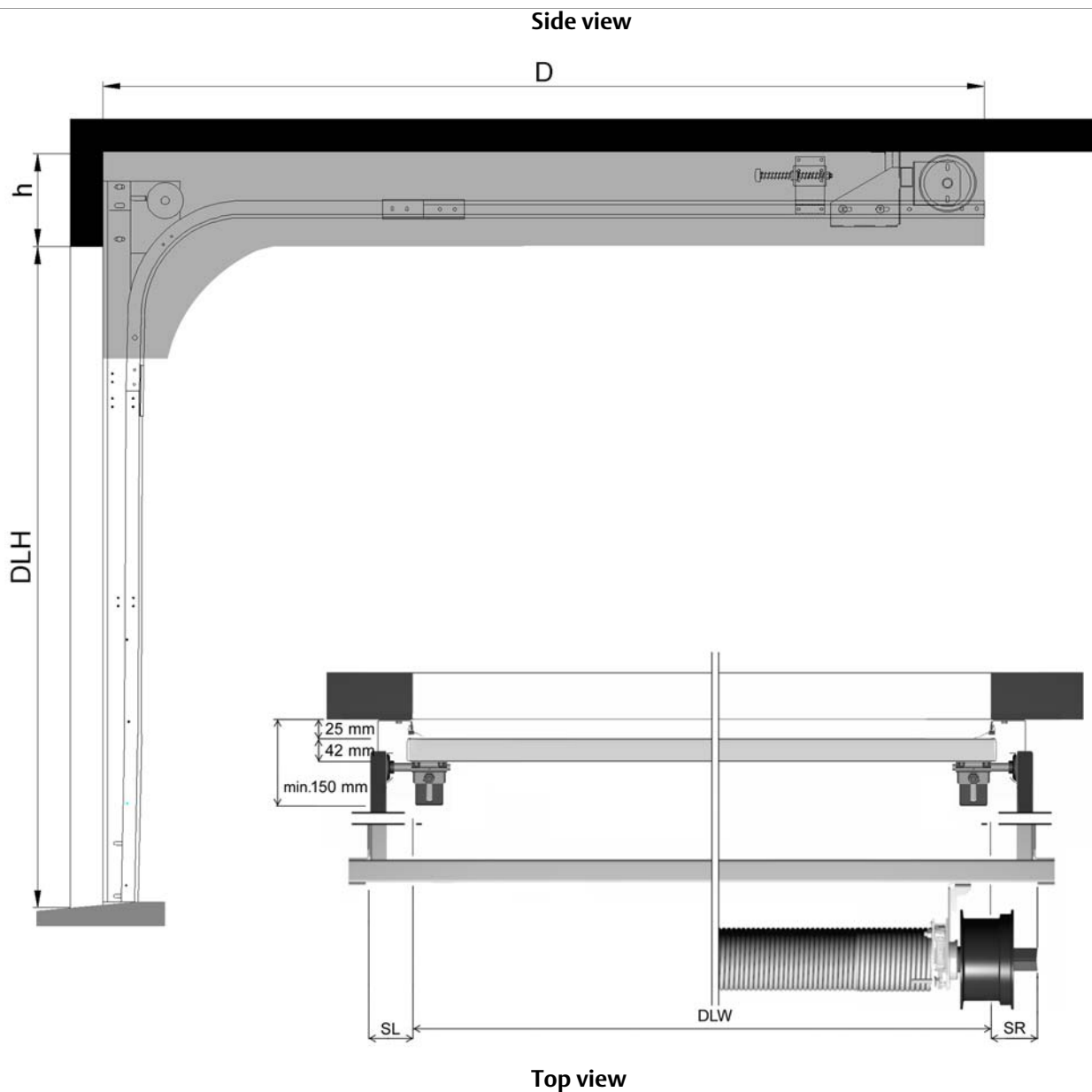

4.2.4 Space requirements VL

DLW *	≤ 8000 mm
DLH	≤ 5500 mm
h	DLH + 400 mm
SL/SR	100 mm
D	if VLA = 450 mm if VLT = 525 mm

* For VL doors: DLW ≤ 3000 mm and DLH ≤ 3350 = VLA = no beam installed

For VL doors: DLW > 3000 mm or DLH > 3350 = VLT = installed beam to support the balancing system

The following doors must be installed on a frame, equipped with an A-65 top seal.

- Doors DLW > 6000 mm
- Doors DLW > 4000 mm with a dark outside colour, installed facing south.

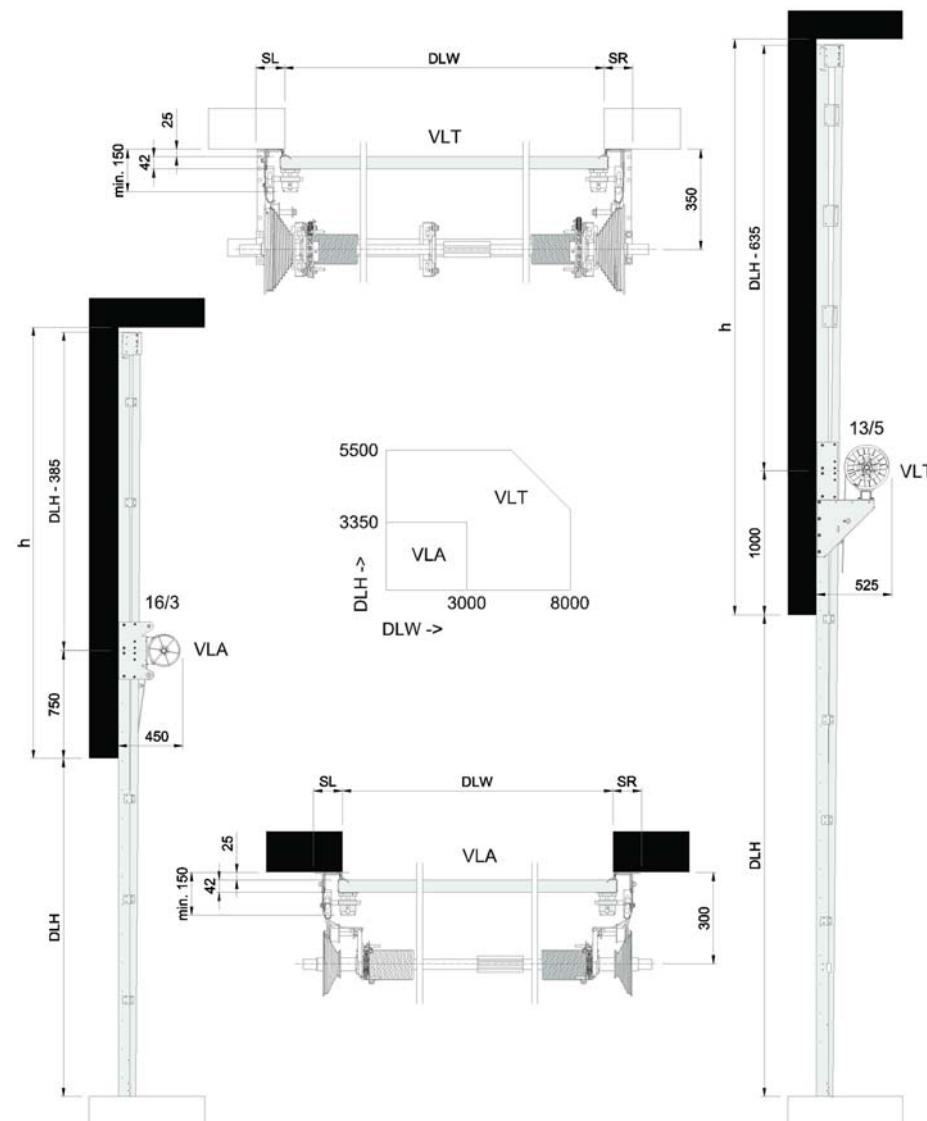



4.2.5 Space requirements Door operators

4.2.5.1 Chain hoist Space requirements

Location	Extra space requirements (mm).		
	D-hoist	T-hoist	U-hoist
Left/right	100	100	200

4.2.5.2 CDM9 (HD / 2H) Installation locations

Location of CDM9 (HD / 2H) operator

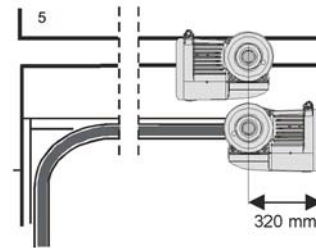
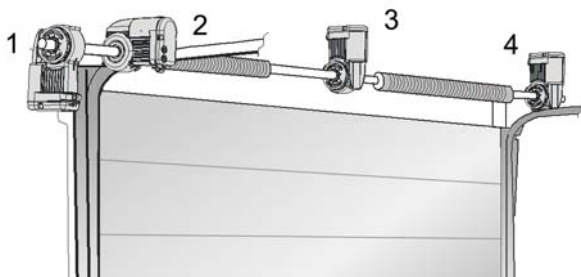

CDM9 (HD / 2H) Space requirements

Location	Extra space requirements (mm).*		
	Side room	Head room	Depth room
1 Left/right	200	0	-
2 Left/right	200	0	-
3 Centre	0	320	-
4 Left/right	200	320	-
5 Centre (Low Lift)	0	0	320

* Space required in addition to the normal space requirements.

5. Service

Preventive Maintenance Program and Modernization Services

As your entrances are part of your business flow, there's every reason to keep them working well. ASSA ABLOY Entrance Systems offers you a maintenance and modernization expertise to rely on. Our Maintenance Programs and Modernization Services are backed by a extensive expertise for all types of industrial door and docking systems, independent of brand. At your disposal is a team of dedicated expert technicians, proven through decades of maintenance, service and satisfied customers.

Preventive Maintenance Programs

Minimizing lost time, lost energy and unexpected hassle is our team's constant objective. Our service organization can support you 24/7 in maintaining all industrial door and docking systems, independent of brand. If you want to be one step ahead of break-downs, explore our portfolio of Pro-Active Care plans. Naturally, we also offer entrance upgrades to suit your specific wishes and business needs.

Pro-Active Care - Maintenance plans to fit your business

Regular maintenance can extend the lifetime of your equipment and help prevent unexpected problems. Our technician arrives on-site equipped with the knowledge and tools to service all automatic entrances, independent of brand.

- **Pro-Active Bronze**

The base on which all Pro-Active Plans are built provides the security of knowing that your equipment is regularly inspected and certified for safety, as well as performing optimally. It includes a number of planned on-site visits depending on your needs. Any unplanned service calls required during the term of the contract (including labor, travel and parts) are billed at special Pro-Active Care prices.

- **Pro-Active Silver**

This plan provides all the benefits of Pro-Active Bronze with the added advantage of labor and travel being included for service calls during regular business hours. The only additional charge would be for any parts that may be needed throughout the term of the contract.

- **Pro-Active Gold**

This plan provides the ultimate protection for your automatic entrance investment. It includes all the benefits of Pro-Active Silver, plus replacement of any parts required during an unplanned repair or planned maintenance visit. Pro-Active Gold is an excellent way to budget your automatic door expenses annually.

- **Pro-Active Tailor-Flex**

Our most flexible maintenance and service offering. The Pro-Active Care plan is designed by you, our customer. The plan allows you to balance your maintenance expenses against your real-world budget and presents the option to add or delete a number of maintenance elements to suit your budget goals, while meeting your overall performance and safety needs.

Modernization

Your entrances are a long-term investment, from which you always want the best. Products develop over time, so do regulations and your business. Let us help you increase energy savings and meet today's standards. We provide advice and modernization kits for outdated installations, ensuring your investment meet requirements and performs optimally for many more years to come.

Re-Active Service		Pro-Active Care				
		Pro-Active Bronze	Pro-Active Silver	Pro-Active Gold	Pro-Active Tailor Flex	
		○	○	○	●	Other customized requests such as Response Time, Performance InfoPack and Advanced User Training
		○	○	●	○	Replacement of worn parts according to preventive Consumable Exchange Program
		○	○	●	○	Replacement of spare parts on breakdowns
		○	●	●	○	Travel and labor for additional call-out visits
		●	●	●	●	Preventive maintenance visits 1-4 times per year
		●	●	●	●	Travel and labor for preventive maintenance visits
		●	●	●	●	Response time and priority on call-outs <24h
		●	●	●	●	Preventive planned maintenance that meets the most demanding standards in the market
	●	●	●	●	●	Safety and quality checks according to applicable regulations and norms. Documentation of test results provided
●	●	●	●	●	●	Documentation of equipment status, assessment and service provided, all generated on site
●	●	●	●	●	●	Highly trained professional technicians with extensive knowledge, state-of-the-art tools and the right spare parts*
●	●	●	●	●	●	Dedicated Professional Customer Care Hotline

● = Included as standard
○ = Available at special prices
* Well-stocked service vehicles with genuine and new spare parts



Index

Numerics

900 Door control systems	20
900 Door control systems - Selection guidelines	28
900 Door control systems - Selection guidelines for automation	28
920 Door control system	20
930 Door control system	20
950 Door control system	20

A

Access and automation	21
Additional functions	23
Air permeability	30
Automatic closing	22
Automatic control functions	22

B

Balancing system	17
Basic control functions	21
Bottom seal	8
Building and space requirements ...	32
Building preparations	32

C

Cable break device (CBD)	17
CDM9 (HD / 2H) Installation locations	38
CDM9 (HD / 2H) Space requirements	38
CDM9 Operator	19
CDM9 Operator - 900 Door control systems	19
CEN Performance	30
Chain hoist	18
Chain hoist Space requirements	38
Colors	7
Construction	7
Copyright and Disclaimer Notice	2
Cylinder lock	9

D

DAOP	10
DARP	10
Daylight width and daylight height	25
Deflection of door panels	32
Description	6
Dimensions	25
Dock management	24
Door leaf	7
Door operation	27

E

Electrical operation	19
Electrical preparations	32
External control functions	21
External push button box	21

F

Facility management	24
Features	3
Fixed sections	11
Frame section	10

G

General	6, 14, 20
---------------	-----------

H

Handle	9
High lift	15

I

Installation preparations	32
Interlocking	21

L

Lifetime expectation	30
Lock bolt	9
Locks	9
Low lift	15

M

Magnetic loop	22
Material	7
Monitoring systems	24

N

Number of windows	26
-------------------------	----

O

Operating forces and safe openings	31
Operating system	18
Optional colours *	7
Options	6

P

Passdoor low threshold	26
Passdoor standard threshold (180mm)	27
Passdoor with low threshold	12
Passdoor with standard threshold (180 mm)	13
Performance	3
Photocell open door	22
Pre-coated colors	7
Pull-down rope	18
Pull-rope switch	21

R

Radar	22
Reduced opening	21
Relay box	23
Remote control	21
Resistance to water penetration	30
Resistance to windload	30

S

Safety devices	17
Safety edge	22
Safety functions	22
Safety photocells 1-channel	22
Safety photocells 2-channel	22
Saving energy	24
Seals	8
Section sizes	25
Security enhancement	24
Selection guidelines for door operator	27
Selection guidelines for operation type	27
Service	39
Side seal	8
Space requirements	33
Space requirements Door operators	38
Space requirements HL	35
Space requirements LL	36
Space requirements SL	34
Space requirements VL	37
Special track sets	16
Specifications	25
Spring break device (SBD)	17
Standard	6
Standard lift	14
Standard lift low	14

T

Technical facts	3
Thermal transmittance	31
Top seal	8
Track sets	14
Traffic lights - Red & Green	23
Types of operation	18

U

UPS battery backup	23
--------------------------	----

V

Vertical cross-section	25
Vertical lift	15

W

Warning lights - Green	23
Warning lights - Red	22
Wind reinforcement truss	8
Windows	10, 26
Windows and passdoor	26

ASSA ABLOY Entrance Systems is a leading supplier of entrance automation solutions for efficient flow of goods and people. With our worldwide presence we offer products and services dedicated to satisfying end-user needs for safe, secure, convenient and sustainable operations. ASSA ABLOY Entrance Systems is a division within ASSA ABLOY.

ASSA ABLOY

www.assaabloyentrance.com